

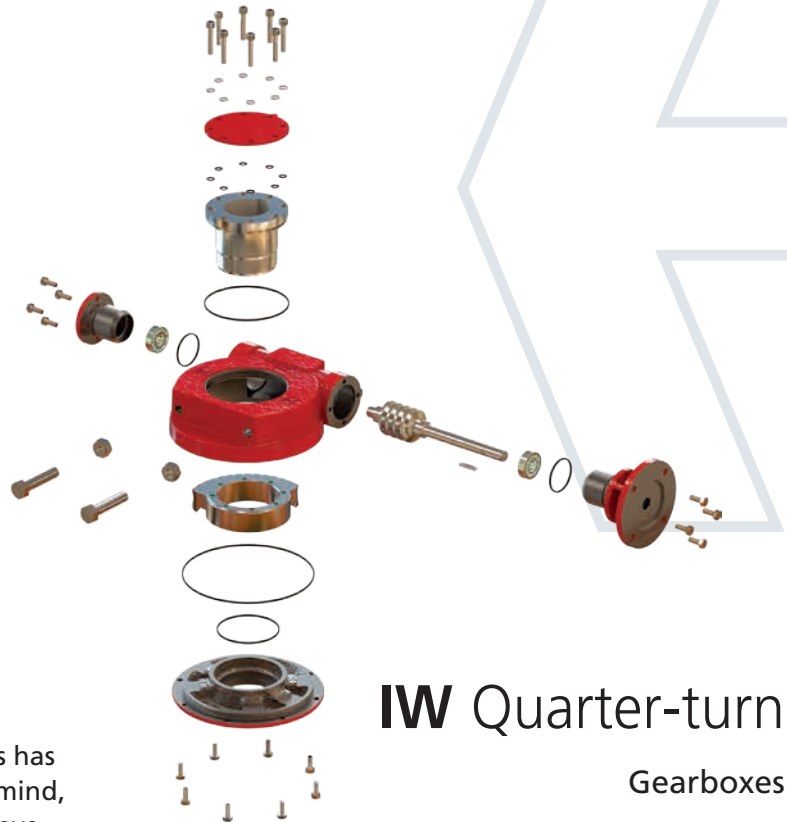

Keeping the World Flowing
for Future Generations



IW Quarter-turn Gear Series

The IW series of quadrant worm operators has been designed with customer stocking in mind, and features a removable steel output sleeve to facilitate bore and keyway machining. This separate output sleeve can be positioned through 90° steps on the IW3 & through 45° steps on the IW4 to IW11. The baseplate can be positioned through 45° steps on the IW3 to IW5 and through 22.5° steps on the IW6 to IW12. This facility allows for on or off centre mounting on the valve spool without special machining.

Operating temperature normally ranges from -40 to +250 °F, although other temperature ranges are available on request. Standard input (for actuation purposes) and output flanges are to MSS SP-101, however, equivalent standards such as ISO can be supplied.

Application

Rotork IW series operators are quarter-turn devices intended for the operation of ball, plug and butterfly valves as well as power and process dampers. The gearboxes are suitable for manual and motorised applications.

Features

- Totally enclosed gearing
- Grease filled for life and fully sealed
- Comprehensive gear ratios combined with a selection of auxiliary input spur gear reducers
- Angular contact bearings supporting worm shaft
- Removable output sleeve
- Repositionable baseplate facility
- Adjustable mechanical stops (at 0° and 90° ±5°)

IW Quarter-turn Gearboxes

Environmental Specification

- Enclosure: IP67 standard suitable for submerged duty up to a depth of 3 feet for 30 minutes
- Temperature: -40 to +250 °F

Options

- Ductile Iron
- IP68
- AWWA, ATEX, Nuclear
- All types of environment
- High temperature range -4 to +302 °F
- Extra high temperature range -4 to +392 °F
- Low temperature range -76 to +250 °F
- Padlockable handwheels
- Limit switches
- Lever arms
- Travelling nut for applications requiring less than 90° travel and more than 90°
- Modulating and multi-turn
- Input flanges for motorisation
- Flexible extensions
- Firesafe to ISO 10497
- Interlock safety system
- Enclosure IP68 suitable for submerged duty up to a depth of 50 feet for 72 hours
- CS type suitable for continuous submerged duty up to a maximum depth of 50 feet

IW Quarter-turn Gearboxes

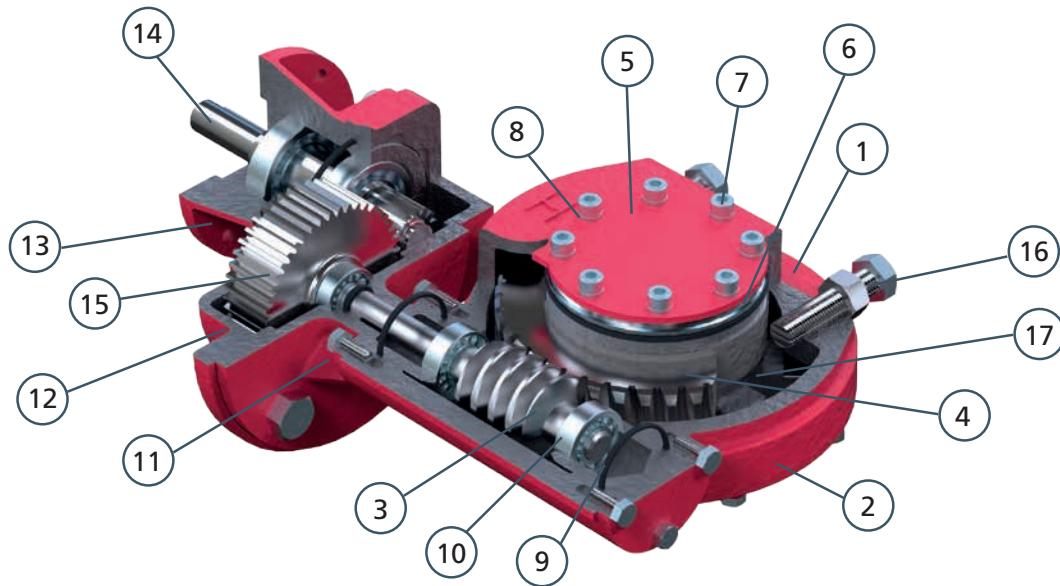

Material Specification for Rotork IW Series of Quarter-turn Valve Operators

No.	Description	Material	UK Standard	USA Standard	DIN Standard
1	Gearcase	SG Iron	BS1563 EN-GJS-450-10 BS1563 EN-GJS-400-15	ASTM A536 65-45-12	GGG40
2	Baseplate	Cast Iron or SG Iron	BS1561 EN-GJL-250 BS1563 EN-GJS-400-15	ASTM A48 35B/40B ASTM A536 65-45-12	GG25 GGG40
3	Worm Shaft	Steel	BS970 045M10 or 605M36T	AISI/SAE 1010 or 4340	C 10 or 42 MnMo 7
4	Quadrant	SG Iron	BS1563 EN-GJS-700-2	ASTM A536 100-70-03	GGG70
5	Position Indicator	Protected Steel	BS970 070M20	AISI/SAE 1023	C 22
6	Output Sleeve	Steel	BS970 070M20 or BS970 080M40 or BS970 070M55	AISI/SAE 1023 or AISI/SAE 1040 or AISI/SAE 1055	C 22 C 40 C 55
7	Drive Screws	Protected Carbon Steel	BS4168		
7a	Drive Screws O-ring	Nitrile Rubber			
8	Nordlock Washers	Protected Steel			
9	Seal	Nitrile Rubber			
10	Bearing	Angular Contact Ball Bearings			
11	Adaptor	Cast Iron	BS1561 EN-GJL-250	ASTM A48 35B/40B	GG25
12	Reducer Gearcase	Cast Iron	BS1561 EN-GJL-250	ASTM A48 35B/40B	GG25
13	Input Flange	Cast Iron or SG Iron	BS1561 EN-GJL-250 BS1563 EN-GJS-400-15	ASTM A48 35B/40B ASTM A536 60-40-18	GG25 GGG40
14	Input Shaft	Steel	BS970 605M36T	AISI/SAE 4340	42 MnMo 7
15	Spur Gear	Steel	BS970 817M40T	AISI/SAE 4340	40 NiCrMo 8 - 4
16	Fasteners	Protected Steel	BS3692		
17	Grease	Renolit CLX2			

Note: Because of the company's policy of continuous improvement, Rotork reserves the right to change specification details without prior notice.

IW Quarter-turn Gearboxes

WORM GEARBOX WITH INPUT REDUCING UNIT FOR ALL RATIOS OTHER THAN BASIC OR GEARBOXES REQUIRING IR3 UNITS OR BEVEL UNITS

BASIC RATIOS: 40:1, 60:1 & 70:1

IR3, IR35 or IR4 INPUT REDUCING UNIT
FITTED TO:
IW9 960:1 TO 3000:1
IW10 180:1 TO 3000:1
IW11 180:1 TO 3000:1
IW115 360:1 TO 900:1
IW12 & IW13 240:1 TO 960:1

STANDARD BASEPLATE

FILLED BASEPLATE

WAFER / ENHANCED BASEPLATE

IW115*, IW12 & IW13 WITH 2ND SPUR AUXILIARY GEARBOX

*IW115 cannot be mounted East for Position A or mounted West for Position B.

Gearbox	Ratio	Input Shaft Diameter (inches)					
		MAN	FA10	FA14	FA16	FA25	FA30
IW3	40 TO 70	0.591	0.591*				
IW4	40 TO 70	0.669	0.669*				
IW4	80 TO 420	0.787	0.787	0.787			
IW5, IW52	40 TO 70	0.984	0.787	0.984			
IW5, IW52	80 TO 420	0.787	0.787	0.787			
IW6, IW62	70	1.181	0.787	1.181	1.181		
IW6, IW62	140 TO 420	0.787	0.787	0.787			
IW63	70	1.181	0.787	1.181	1.181		
IW63	140 TO 420	-	0.787	0.787			
IW7, IW72	60	1.181	0.787	1.181	1.181	1.181	
IW7, IW72	120 TO 720	1.969	0.787	1.181			
IW8, IW82	60	1.575	-	-	1.575	1.575	
IW8, IW82	120 TO 720	1.969	0.787	1.181	1.575	1.969	
IW9	60	-	-	-	1.575	1.969	
IW9	180 TO 3000	1.969	0.787	1.181	1.575	1.969	
IW10	60	-	-	-	-	1.969	1.969
IW10	180 TO 3000	1.969	0.787	1.181	1.575	1.969	
IW11, IW115	60	-	-	-	-	1.969	1.969
IW11	180 TO 3000	1.969	0.787	1.181	1.575	1.969	
IW115	360 TO 900	1.969	-	1.181	1.575	1.969	
IW12, IW13	60	-	-	-	-	2.953	2.953
IW12, IW13	240 TO 960	-	-	1.181	1.575	1.969	
IW115, IW12 & IW13 WITH 2ND SPUR AUXILIARY							
IW115	1190 TO 5390	1.181	0.787	1.181	1.181		
IW12, IW13	1290, 1210 TO 5760	1.181	0.787	1.181	1.181		
*0.787 INCH SHAFT ADAPTOR AVAILABLE ON REQUEST				SHAFT TOLERANCE -0.002			

IW Quarter-turn Gearboxes

Dimensions and Weights

Gearbox	Ratio	ØA	B	C	D	E	F	G	H	ØI	Weight (lb)
IW3	40, 70	6.77	2.99		4.65	6.22	3.58	2.91	1.93		24
IW4	40, 70	8.58	4.02		5.59	7.17	4.02	3.35	1.97		49
IW4	80, 120, 140, 160, 210, 280	8.58	4.02	2.52	10.59	12.60	4.09	3.35	1.97	7.48	66
IW4	200, 240, 350, 420	8.58	4.02	3.78	11.46	13.46	4.09	3.35	1.97	9.76	77
IW5 / IW52	40, 70 / 40	11.22	5.35		7.32	9.29	5.20	4.49	2.72		99
IW5	80, 120, 140, 160, 210, 280	11.22	5.35	2.52	12.32	14.33	5.20	4.49	2.72	7.48	117
IW5	200, 240, 350, 420	11.22	5.35	3.78	13.19	15.20	5.20	4.49	2.72	9.76	128
IW52	80, 120, 160	11.22	5.35	2.52	12.32	14.33	5.20	4.49	2.72	7.48	117
IW52	200, 240	11.22	5.35	3.78	13.19	15.20	5.20	4.49	2.72	9.76	128
IW6, IW62, IW63	70	14.76	7.01		7.32	9.29	5.47	4.45	2.76		150
					7.72 for F10, FA10						
IW6, IW62, IW63	140 - 280	14.76	7.01	2.52	12.32	14.33	5.47	4.45	2.76	7.48	174
IW6, IW62, IW63	350 - 420	14.76	7.01	3.78	13.46	15.47	5.47	4.45	2.76	9.76	185
IW7, IW72	60	17.72	8.27		10.63	12.95	6.73	5.51	3.39		265
IW7, IW72	120 - 360	17.72	8.27	4.69	18.11	20.51	6.73	5.51	3.39	11.42	335
IW7, IW72	480 - 720	17.72	8.27	7.05	18.46	20.87	6.73	5.51	3.39	16.06	357
IW8, IW82	60	20.47	9.69		12.05	14.37	7.56	6.30	3.90		397
IW8, IW82	120 - 360	20.47	9.69	4.69	19.53	21.93	7.56	6.30	3.90	11.42	467
IW8, IW82	480 - 720	20.47	9.69	7.05	19.88	22.28	7.56	6.30	3.90	16.06	489
IW9	60	23.46	10.98		14.61	18.94	7.87	6.61	3.90		485
IW9	180 - 720	23.46	10.98	7.05	22.36	24.84	7.87	6.61	3.90	16.06	578
IW9	960 - 3000	23.46	10.98	2.32	23.82	26.22	7.87	6.61	3.90	15.04	639
IW10	60	28.94	13.50		15.63	19.96	8.50	7.09	4.33		728
IW10	180 - 3000	28.94	13.50	2.32	24.84	27.24	8.50	7.09	4.33	15.04	899
IW11 / IW11BB	60	31.30	15.00		16.30	20.63	9.72	7.87	4.72		1146
IW11 / IW11BB	180 - 3000	31.30	15.00	2.32	25.51	27.91	9.72	7.87	4.72	15.04	1257
IW115 / IW115BB	60	31.30	15.00		16.30	20.63	9.72	7.87	4.72		1146
IW115 / IW115BB	360 - 900	31.30	15.00	2.32	25.51	27.91	9.72	7.87	4.72	15.04	1190
IW115 WITH 2ND SPUR AUXILIARY	1190 - 5390	31.30	15.00	9.45	30.98	32.95	9.72	7.87	4.72	15.04	1257
IW12, IW13	60	38.27	17.72		18.11	24.02	10.24	9.88	6.54		2205
IW12, IW13	240 - 960	38.27	17.72	9.45	33.50	35.83	10.24	9.88	6.54	20.47	2535
IW12 WITH 2ND SPUR AUXILIARY	1290 - 5760	38.27	17.72	8.03	38.94	40.91	10.24	9.88	6.54	20.47	2579
IW13 WITH 2ND SPUR AUXILIARY	1210 - 5760	38.27	17.72	12.01	39.41	41.38	10.24	9.88	6.54	20.47	2601

All dimensions in inches.

Mounting Options

Gearbox	Max Bore ANSI B17.1 Key		Max Square Bore AF	MSS Flange Standard Baseplate	MSS Flange Filled Baseplate	MSS Flange Enhanced Baseplate	Filled Baseplate Thickness	Enhanced Baseplate Thickness
	Square	Rectangular						
IW3	1.75	1.75	1.375	FA10 - FA12	-	FA14 - FA16	-	0.87
IW4	2.25	2.5	2	FA10 - FA12 - FA14	-	FA16	-	0.98
IW5, IW52	2.75	3	2.375	FA14 - FA16	FA25	FA25	0.24	1.26
IW6, IW62, IW63	3.75	3.875	3.25	FA16 - FA25	FA16 - FA25 - FA30	FA30	0	0.91
IW7, IW72	4.875	5.25	4.25	FA25 - FA30	FA30	FA35	0.39	1.22
IW8, IW82	5.625	6	4.75	FA25 - FA30 - FA35 - FA40	FA25 - FA30 - FA35	FA40 - FA48	0	1.50
IW9	6.5	6.5	5.125	FA30 - FA35 - FA40	FA30 - FA35 - FA40	FA40 - FA48	0	1.06
IW10	7.375	7.625	6	FA35 - FA40 - FA48	FA48	FA60	0	1.26
IW11, IW115	7.375	7.625	6	FA35 - FA40 - FA48	FA60	-	0	-
IW11BB, IW115BB	9.875	10.125	7.5	FA40 - FA48	FA60	-	0	-
IW12, IW13	9.5	10.25	7	FA35 - FA40 - FA48	-	-	-	-
IW12, IW13	11.75	12	9	FA48 - FA60	-	-	-	-

Customer Drive and Orientation Options

IW3 TO IW13 40:1 TO 70:1

INPUT SHAFT PROJECTION WITHOUT INPUT REDUCER

DRIVE OPTIONS

KEYWAY POSITIONS WITH GEARBOX IN CLOSED POSITION

SQUARE BORE

PARALLEL
(FLATS ON CENTRE)

DIAGONAL
(FLATS OFF CENTRE)

SLOTTED BORE

FLATS ACROSS
FLOW LINE

FLATS ON
FLOW LINE

INPUT SHAFT PROJECTION

IW4 TO IW9 UP TO 720:1
IW12 & IW13 RATIOS 240:1 TO 960:1

INPUT REDUCER ORIENTATION POS. A

INPUT REDUCER ORIENTATION POS. B

INPUT SHAFT PROJECTION

IW9 960:1 TO 3000:1 **IW115 360:1 TO 900:1**

IW10 & IW11 180:1 TO 3000:1

IR3 INPUT REDUCER ORIENTATION POS. A

IR3 INPUT REDUCER ORIENTATION POS. B

INPUT SHAFT PROJECTION

IW115, IW12 & IW13 WITH 2ND SPUR AUXILIARY GEARBOX

2ND AUXILIARY GEARBOX ORIENTATION POS. A WITH 1ST AUXILIARY SHOWN IN EAST
DEFAULT ORIENTATION EAST/EAST

2ND AUXILIARY GEARBOX ORIENTATION POS. B WITH 1ST AUXILIARY SHOWN IN WEST
DEFAULT ORIENTATION WEST/WEST

*IW115 1ST AUXILIARY SPUR CANNOT BE MOUNTED EAST FOR POSITION A OR MOUNTED WEST FOR POSITION B, DEFAULT ORIENTATION POS. B EAST/WEST.

A1 = Anticlockwise in, clockwise out. A2 = Clockwise in, clockwise out. B1 = Clockwise in, clockwise out. B2 = Anticlockwise in, clockwise out.

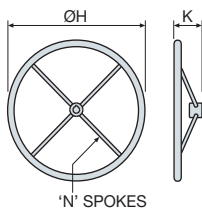

Dimensions

Type	ØH	K	N
F200	8	2.97	3
F300	12	3.96	3
F400	16	3.96	4
F500	20	3.96	4
F600	24	3.96	4
F700	28	3.96	6
F800	32	3.96	6
F900	36	3.96	6
F1000	40	3.96	6
F1100	44	3.96	6
F1200	48	3.96	8

'F' Type handwheel

